

SECTION A-A

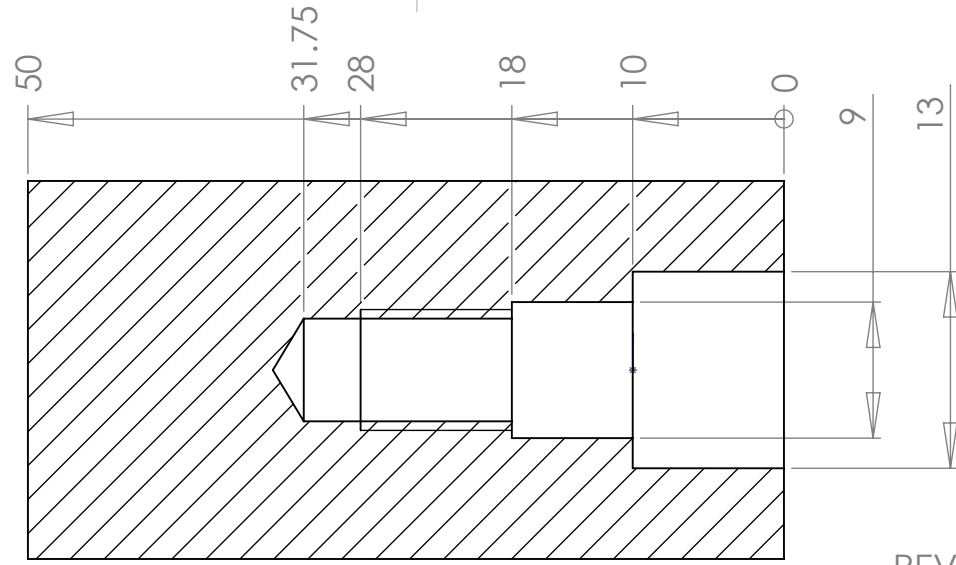

$\varnothing 6.80 \nabla 13.75$
 REVERSED M8x1.25 - 6H $\nabla 10$

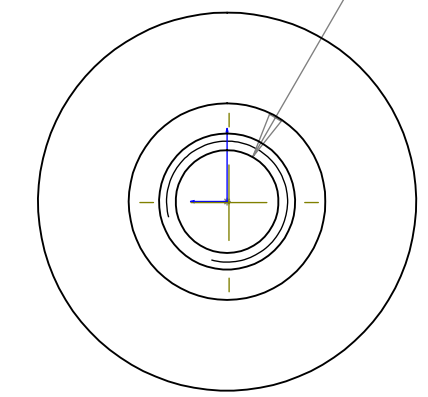
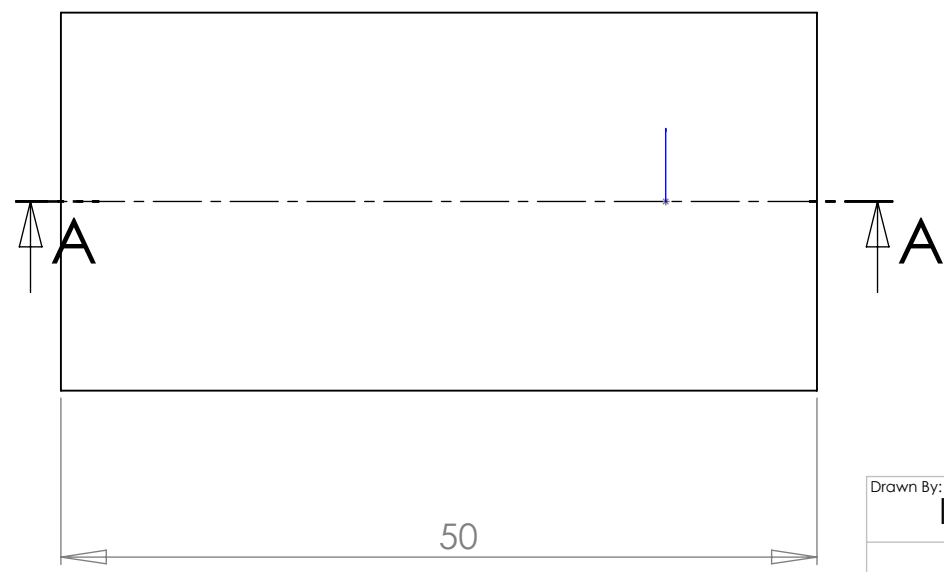
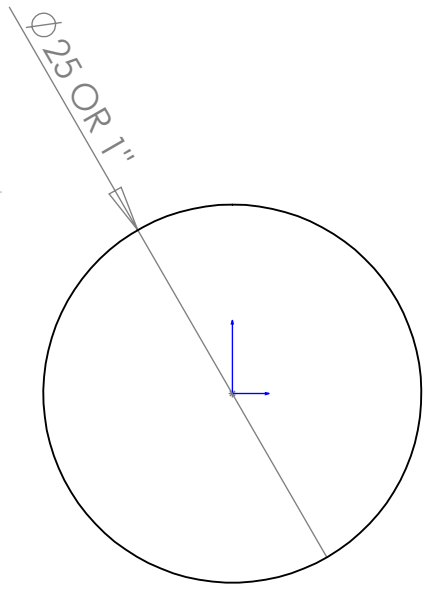

Drawn By: **lucy** Date: **30may08**

Any Questions Please contact:
 lucy@magnificentrevolution.org
 07793 767 914

MATERIAL: Stainless 316	DWG NO. 09-01-19 Threaded
Notes: Clean and Deburred	SCALE:2:1 SHEET 1 OF 1